

Some Applications of First-Order Differential Equations

Aye Aye Khaing^{*}, Daw Cho^{**}

Abstract

In this paper, the population growth and decay of a substance are analyzed. Finally, the chemical concentrations of the rate of entering, the rate of leaving and the amount of chemical in a container are evaluated.

Keywords : First-order differential equation, First-order initial value problem, separation of variable

1. Introduction

A first –order differential equation is an equation that contain only first derivative, and it has many applications in mathematics, physics, engineering and many other subjects. In this paper, we discussed the applications of the following linear differential equations:

- (i) Population growth and decay, and
- (ii) Mixing problems.

2. Population Growth and Decay

2.1 Exponential Change

In real life, a quantity y increases or decreases at a rate proportional to its size at time t . These quantities include the amount of a decaying radioactive material and the size of a population. Such quantities are said to yield exponential change.

We can find $y = y(t)$ when $t = 0$ and $y = y_0$.

And we solve the initial value problem as follows:

$$\frac{dy}{dt} = ky \tag{1}$$

$$y = y_0 \text{ when } t = 0. \tag{2}$$

If $y > 0$ and y is increasing then $k > 0$.

If $y > 0$ and y is decreasing then $k < 0$.

If $y_0 = 0$ then $y = 0$ is a solution of Equation (1).

For $y \neq 0$,

$$\frac{1}{y} \frac{dy}{dt} = k.$$

* Lecturer, Department of Mathematics, Yadanabon University

** Professor, Dr, Department of Mathematics, Yadanabon University

Integrating both sides, we get

$$\begin{aligned}\ln|y| &= kt + C \\ |y| &= e^{kt+C} \\ y &= \pm e^{kt} e^C \\ y &= Ae^{kt} \quad \text{where } A = \pm e^C.\end{aligned}$$

Take $A = 0$, then $y = 0$ is the solution in the formula.

We will find A when $y = y_0$ and $t = 0$,

$$y_0 = Ae^{k \cdot 0} = A.$$

Therefore, $y = y_0 e^{kt}$ (3)

is the solution of the initial value problem.

Quantities changing in this way are said to yield exponential growth if $k > 0$ and exponential decay if $k < 0$ where k is called the rate constant of the change.

An important property of a radioactive material is the length of time T , it takes to decay to one-half the initial amount. This is known as half-life. We calculate for T ,

$$\begin{aligned}\frac{1}{2}y_0 &= y_0 e^{-kT} \\ e^{-kT} &= \frac{1}{2} \\ -kT &= \ln\left(\frac{1}{2}\right) \\ &= -\ln 2 \\ T &= \frac{\ln 2}{k}.\end{aligned}\quad (4)$$

2.2 Example

A radioactive substance has a half-life of 1720 years. If its mass is 6 grams, we can find to how much will be left 860 years from now and the time t_1 when 2.5 grams of the substance remain.

From Equation (3), we get $t_0 = 0$ and $y_0 = 6$,

$$y(t) = 6e^{-kt}.\quad (5)$$

From Equation (4), we obtain $T=1720$ years.

$$\begin{aligned}k &= \frac{\ln 2}{T} \\ &= \frac{\ln 2}{1720}.\end{aligned}$$

Substituting k in Equation (5), we get

$$y(t) = 6e^{-(t \ln 2)/1720}.\quad (6)$$

Thus, the mass left after 860 years is

$$\begin{aligned} y(860) &= 6e^{-(860\ln 2)/1720} \\ &= 6e^{-\ln 2/2} \\ &= 4.24 \text{ grams.} \end{aligned}$$

Putting $t = t_1$ in Equation (6) and $y(t_1) = 2.5$, we obtain

$$\frac{5}{2} = 6e^{-(t_1 \ln 2)/1720}.$$

Dividing by 6 and taking logarithms, we get

$$\ln \frac{5}{12} = -\frac{t_1 \ln 2}{1720}.$$

$$\text{Since } \ln \frac{5}{12} = -\ln \frac{12}{5},$$

$$\begin{aligned} t_1 &= 1720 \frac{\ln(12/5)}{\ln 2} \\ &\approx 2172.42 \text{ years.} \end{aligned}$$

2.3 Example

The populations of Mandalay are 1108000 in 2010 and 1138000 in 2011. Assume that its populations will continue to grow exponentially at a constant rate. It was found that the populations can expect in the year 2026.

Using the initial boundary conditions, we get

$$y(t) = 1108000e^{kt}. \quad (7)$$

To determine the growth constant k , we use $y(1) = 1138000$

$$\begin{aligned} 1138000 &= 1108000e^k \\ e^k &= \frac{1138}{1108} \end{aligned}$$

$$\begin{aligned} k &= \ln\left(\frac{1138}{1108}\right) \\ k &= 0.026716. \end{aligned}$$

Substituting k in Equation (7), we get

$$y(t) = 1108000e^{0.026716t}$$

For $t = 15$,

$$\begin{aligned} y(15) &= 1108000e^{(0.026716)(15)} \\ &\approx 1654165.3946. \end{aligned}$$

In the year 2026, the population size is expected to be 1654165.

3. Mixing Problems

3.1 Statement of the Problem

Consider the situation described in Figure 1. A tub initially contains V_0 liters of a solution in which A_0 grams of a certain chemical is dissolved. A solution containing c_1 grams/liter of the same chemical flows into the tub at a constant rate of r_1 liters/minute, and the mixture flows out at a constant rate of r_2 liters/minute. It is thought that the mixture is kept uniform by stirring. Then for any time t the concentration of chemical in the tub, $c_2(t)$ is the same throughout the tub and is given by

$$c_2 = \frac{A(t)}{V(t)}, \quad (8)$$

where $V(t)$ is the volume of solution in the tub at time t and $A(t)$ is the amount of chemical in the tub at time t .

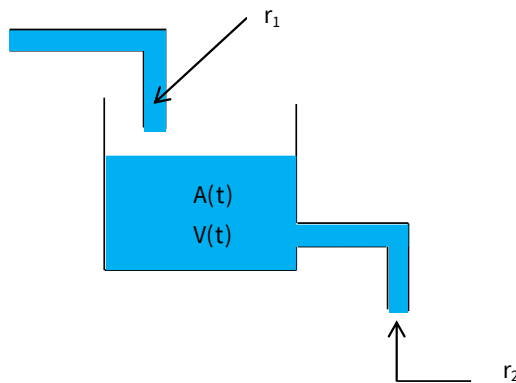

Figure 1. A Mixing Problem

3.2 Mathematical Formulation

We consider $V(t)$ and $A(t)$ change during a short time interval Δt minutes. In time Δt , $r_1 \Delta t$ liters of solution flow into the tub, whereas $r_2 \Delta t$ liters flow out. Thus, the change in the volume of solution in the tub during the time interval Δt is

$$\Delta V = r_1 \Delta t - r_2 \Delta t = (r_1 - r_2) \Delta t. \quad (9)$$

Since the concentration of chemical in the flow is c_1 grams/liter, it follows that in the time interval Δt the amount of chemical that flows into the tub is $c_1 r_1 \Delta t$.

Similarly, the amount of chemical that flows out in this same time interval is approximately $c_2 r_2 \Delta t$. Since ΔA is the total change in the amount of chemical in the tub during the time interval Δt , we get

$$\Delta A \approx c_1 r_1 \Delta t - c_2 r_2 \Delta t = (c_1 r_1 - c_2 r_2) \Delta t \quad (10)$$

Dividing Equations (9) and (10) by Δt , we obtain

$$\frac{\Delta V}{\Delta t} = r_1 - r_2 \quad \text{and} \quad \frac{\Delta A}{\Delta t} \approx (c_1 r_1 - c_2 r_2).$$

These equations show the rates of change of V and A over the short, but finite, time interval Δt .

To determine the instantaneous rates of change of V and A, taking $\Delta t \rightarrow 0$, we obtain

$$\frac{dV}{dt} = r_1 - r_2 \quad (11)$$

and
$$\frac{dA}{dt} = c_1 r_1 - \frac{A}{V} r_2, \quad (12)$$

where we have substituted for c_2 from Equation (8).

Since r_1 and r_2 are constants, we can integrate Equation (11), we get

$$V(t) = (r_1 - r_2)t + V_0,$$

where V_0 is an integration constant. Substituting for V into Equation (12) and rearranging terms implies the linear equation for A(t):

$$\frac{dA}{dt} + \frac{r_2}{(r_1 - r_2)t + V_0} A = c_1 r_1. \quad (13)$$

We can find A(t) from Equation (13) using the initial condition $A(0) = A_0$.

3.3 Example

A tub initially contains 100 gal of salt water in which 50lb of salt are dissolved. Salt water containing 2lb/gal of salt runs into the tub at the rate of 5gal/min. The maximum is kept uniform by stirring and it flows out of the tub at the rate of 4 gal/min. We can find the rate of salt which enters the tub at the time t, the volume of salt water in the tub at time t, the rate of salt which leaves the tub at time t. Then we solve the initial value problem describing the mixing process and the concentration of salt in the tub 25 min after the process starts.

We can find the rate entering,

$$c_1 r_1 = 2 \text{ lb / gal} \cdot 5 \text{ gal / min} = 10 \text{ lb / min}.$$

Let V(t) be the total volume of salt water in the tub at time t. Then

$$\begin{aligned} V(t) &= V_0 + (r_1 - r_2)t \\ &= 100 + (5 - 4)t \\ &= (100 + t) \text{ gal.} \end{aligned}$$

We get the volume at time t is (100+t) gal. The amount of salt in the tub at time t is A lbs.

So the concentration at any time t is $\frac{A}{100 + t}$ lb / gal.

Then, we obtain the rate leaving $\frac{4A}{100 + t}$ lbs/ min.

So, the differential equation modeling the mixture process is

$$\frac{dA}{dt} = \left[10 - \frac{4A}{100 + t} \right] \text{ lb / min}.$$

To solve this differential equation, we write

$$\frac{dA}{dt} + \frac{4A}{100+t} = 10.$$

Thus, $P(t) = \frac{4A}{100+t}$ and $Q(t) = 10$.

The integrating factor is

$$\begin{aligned} v(t) &= e^{\int \frac{4}{100+t} dt} \\ &= e^{\ln(100+t)^4} \\ &= (100+t)^4. \end{aligned}$$

Multiplying both sides of the standard equation by $v(t)$ and integrating both sides, we get

$$\begin{aligned} (100+t)^4 \left(\frac{dA}{dt} + \frac{4}{100+t} A \right) &= 10(100+t)^4 \\ (100+t)^4 \frac{dA}{dt} + 4(100+t)^3 A &= 10(100+t)^4 \\ \frac{d}{dt} [(100+t)^4 A] &= 10(100+t)^4 \\ (100+t)^4 A &= \int 10(100+t)^4 dt \\ A &= \frac{10}{(100+t)^4} \left(\frac{(100+t)^5}{5} + C \right). \end{aligned}$$

We can find the general solution is

$$A = 2(100+t) + \frac{C}{(100+t)^4}.$$

Substituting $A = 50$ when $t = 0$, we obtain the value of $C = -(150)(100)^4$.

In particular solution of the initial value problem is

$$\begin{aligned} A &= 2(100+t) - \frac{(150)(100)^4}{(100+t)^4} \\ A &= 2(100+t) - \frac{150}{\left(1 + \frac{t}{100}\right)^4}. \end{aligned}$$

We can observe the concentration of salt in the tub 25 min after the process starts:

$$\begin{aligned} A &= 2(100+t) - \frac{(150)(100)^4}{(100+t)^4} \\ &\approx 188.56 \text{ lbs.} \end{aligned}$$

So, the concentration is $\frac{A(25)}{V} \approx \frac{188.56}{125} \approx 1.5 \text{ lb / gal}$.

3.4 Example

A tub contains 100 gal of water. A solution containing 1lb/gal of fertilizer runs into the tub at the rate of 1 gal/min, and the mixture is pumped out of the tub at the rate of 3 gal/min. Find the maximum amount of fertilizer in the tub and the time required to reach the maximum.

Let A be the amount (in pounds) of fertilizer in the tub at time t. We know that $A = 0$ when $t = 0$. Then the number of gallons of water and fertilizer in solution in the tub at any time is

$$\begin{aligned} V(t) &= V_0 + (r_1 - r_2)t \\ &= 100 \text{ gal} + (1\text{gal / min} - 3\text{gal / min})(t \text{ min}) \\ &= (100 - 2t)\text{gal}. \end{aligned}$$

The differential equation modeling the mixture process is

$$\begin{aligned} \frac{dA}{dt} &= c_1 r_1 - \frac{A(t)}{V(t)} r_2 \\ &= 1.1 - \frac{A}{(100 - 2t)} \cdot 3 \\ \frac{dA}{dt} &= \left[1 - \frac{3A}{100 - 2t}\right] \text{lb/ min}. \end{aligned}$$

We solve this differential equation,

$$\frac{dA}{dt} + \frac{3A}{100 - 2t} = 1.$$

Thus,

$$P(t) = \frac{3}{100 - 2t} \text{ and } Q(t) = 1.$$

The integrating factor is

$$\begin{aligned} v(t) &= e^{\int P dt} \\ &= e^{\int \frac{3}{100 - 2t} dt} \\ &= e^{-\frac{3}{2} \ln(100 - 2t)} \\ &= e^{\ln(100 - 2t)^{-3/2}} \\ &= (100 - 2t)^{-3/2}. \end{aligned}$$

Multiplying both sides of the standard equation by $v(t)$ and integrating both sides, we obtain

$$\begin{aligned} \frac{d}{dt} \left[(100 - 2t)^{-3/2} A \right] &= (100 - 2t)^{-3/2} \\ (100 - 2t)^{-3/2} A &= \int (100 - 2t)^{-3/2} dt \\ (100 - 2t)^{-3/2} A &= \frac{(100 - 2t)^{-1/2}}{\left(-\frac{1}{2}\right)(-2)} + C. \end{aligned}$$

The general solution is

$$\begin{aligned} A &= \frac{(100 - 2t)^{-1/2}}{(100 - 2t)^{-3/2}} + \frac{C}{(100 - 2t)^{-3/2}} \\ A &= (100 - 2t) + C(100 - 2t)^{3/2}. \end{aligned}$$

If $t = 0$, then $A = 0$ and so the value of $C = -\frac{1}{10}$.

In particular solution, the initial value problem is

$$\begin{aligned} A &= (100 - 2t) - \frac{1}{10}(100 - 2t)^{3/2} \\ \frac{dA}{dt} &= -2 - \frac{1}{10} \left(\frac{3}{2}\right)(100 - 2t)^{1/2}(-2). \end{aligned}$$

If $\frac{dA}{dt} = 0$, then

$$-2 + \frac{3}{10}\sqrt{100 - 2t} = 0$$

$$\sqrt{100 - 2t} = \frac{20}{3}$$

$$100 - 2t = \left(\frac{20}{3}\right)^2$$

$$t = 50 - 22.22$$

$t \approx 27.78$ min, the time to reach the maximum.

Thus, the maximum amount is $A(27.8) \approx 14.8$ lb.

4. Result and Discussion

This paper attempted to discuss the application of first order differential equation by using modeling phenomena of real world problems. This result found here may be very useful in the study of increasing or decreasing of a population in nature. Moreover, mixing problems solves by using first-order linear differential equations. From this discussion, some idea how differential equations are closely associated with mathematical applications is obtained and also how the law of nature in different fields of science is formulated in terms of differential equations.

Conclusion

Many fundamental problems are expressed by systems of linear differential equations in sciences and engineering. By the system of linear first order differential equations, we estimate the human population. Some problems induce the development of applied mathematics. In this paper, we study on applications of differential equation and their solutions essential with this regard.

Acknowledgements

I would like to express my sincere gratitude to Rector, Dr. Tint Moe Thuzar and Pro-rectors Dr. U Khin Myot, Dr. Myint Myint Oo and Dr. Khin Maw Maw Soe, Yadanabon University for their permission to perform this research paper. And then, I am greatly indebted to Professor Dr. Mon Yee Aye, Head of Department of Mathematics, Yadanabon University for her encouragement to this research paper.

References

- Population growth and decay. [Online]. Available: <https://www.math.uh.edu/~almus/4389-DE-ch2.pdf>.
- Richard. B., Theory and Problems of Differential Equations, Second Edition, Mc graw-Hill., Inc, Singapore, 1994.
- Thomas. G. B. Jr., " Thomas' Calculus", Twelfth Edition, Addison-Wesley, New York,2010.
- Tyn Myint-U, " Partial Differential Equations for Scientists and Engineers", Third Edition, Prentice-Hall, Inc, 1987.